

# Hi-MO X10 Guardian Anti-Dust

## LR8-66HVDF

### 640~670M



#### Patented Frame Design:

Effectively Reduces Dust Accumulation Impact, Boosting Power Generation by 2%+.



#### Scenario Adaptation:

Ideal for bifacial gain scenarios, including cement roofs and carport structures.



#### Safe:

Prevent Overheating, Lower temperature under shade 60°C+<sup>1</sup> compare with conventional modules



#### Value-Added:

A+ Anti-Shading<sup>2</sup>, Less Loss.



**Bifacial  
Power Generation**

**15Y** Product Warranty | **30Y** Performance Warranty

#### Complete System and Product Certifications

IEC 61215, IEC 61730

IEC62941: Guideline for module design qualification and type approval

ISO9001: Quality Management System

ISO14001: Environment Management System

ISO45001: Occupational Health and Safety



**24.80%**

 MAX MODULE  
EFFICIENCY

**1%**

 FIRST YEAR  
POWER DEGRADATION

**0.35%**

 YEAR 2-30  
POWER DEGRADATION

**-0.26%/°C**

 BETTER TEMPERATUR  
COEFFICIENT

**Mechanical Parameters**

Cell Orientation	132 (6×22)
Junction Box	IP68, three diodes
Output Cable	4mm <sup>2</sup> ; +400/-200mm/±1400mm length can be customized
Glass	Dual glass, 2.0+2.0mm semi-tempered glass
Frame	Anodized aluminum alloy frame
Weight	32.5 kg
Dimension	2382×1134×30mm
Packaging	35pcs per pallet / 140pcs per 20'GP / 700pcs per 40'HC

Remark: 17.5m trucks are rated at 30t load. Actual loading quantity is subject to vehicle specs.

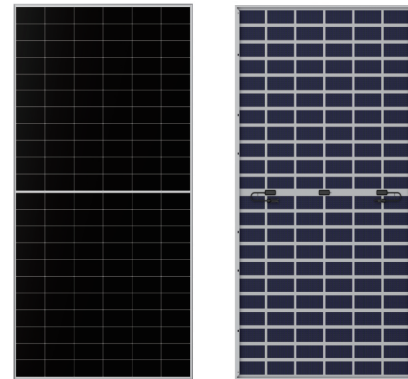
**Electrical characteristics with different rear side power gain**

Pmax/W	Voc/V	Isc/A	Vmp/V	Imp/A	Pmax gain
645	49.62	16.46	40.88	15.78	0%
677	49.62	17.28	40.88	16.57	5%
710	49.62	18.11	40.88	17.36	10%
744	49.72	18.93	40.98	18.15	15%
776	49.72	19.75	40.98	18.94	20%
808	49.72	20.58	40.98	19.73	25%

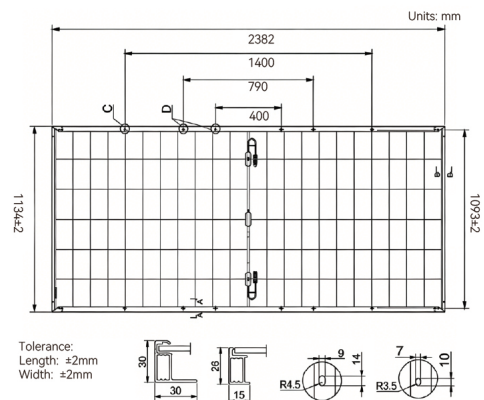
**Electrical Characteristics** -STC: Irradiance1000W/m<sup>2</sup>, Cell Temperature 25°C, AM1.5 (Test uncertainty for Pmax: ±3%)

Module Type	LR8-66HVDF-640M	LR8-66HVDF-645M	LR8-66HVDF-650M	LR8-66HVDF-655M	LR8-66HVDF-660M	LR8-66HVDF-665M	LR8-66HVDF-670M
Testing Condition	STC	STC	STC	STC	STC	STC	STC
Maximum Power (Pmax/W)	640	645	650	655	660	665	670
Open Circuit Voltage (Voc/V)	49.52	49.62	49.72	49.82	49.92	50.02	50.12
Short Circuit Current (Isc/A)	16.38	16.46	16.54	16.62	16.70	16.78	16.86
Voltage at Maximum Power (Vmp/V)	40.78	40.88	40.98	41.08	41.18	41.28	41.38
Current at Maximum Power (Imp/A)	15.69	15.78	15.86	15.94	16.03	16.11	16.19
Module Efficiency (%)	23.69	23.88	24.06	24.25	24.43	24.62	24.80

**Operating Parameters**

Module [T98] Max	70°C
Operational Temperature	-40°C ~ +85°C
Power Output Tolerance	0~3%
Maximum System Voltage	DC1500V (IEC)
Maximum Series Fuse Rating	35A
Nominal Operating Cell Temperature	45±2°C
Protection Class	Class II
Bifaciality	φPmax: 75±5%
Fire Rating	IEC Class C

**Mechanical Loading**

Min Designed Mechanical Load	1600Pa/1600Pa
Front Side Maximum Static Loading	5400Pa
Rear Side Maximum Static Loading	2400Pa
Hailstone Test	25mm Hailstone at the speed of 23m/s

**Temperature Ratings (STC)**

Temperature Coefficient of Isc	+0.050%/°C
Temperature Coefficient of Voc	-0.200%/°C
Temperature Coefficient of Pmax	-0.260%/°C